



15 Frame Plunger Pump

Standard Brass Model

1050

Stainless Steel Model

1051

Nickel Aluminum Bronze Model

1057

FEATURES

Superior Design

- Triplex plunger design gives smoother liquid flow.
- V-Packings are completely lubricated and cooled by the liquid being pumped.
- Inlet and discharge valve assemblies interchange for easier maintenance.
- Lubricated Lo-Pressure Seals provide double protection against external leakage.
- Oil bath crankcase assures optimum lubrication.
- Close tolerance concentricity of the ceramic plunger maximizes seal life.

Quality Materials

- All stainless steel valves are heat treated and seats are roller burnished for a positive seal and extended valve life.
- Brass, Stainless Steel or Nickel Aluminum Bronze manifolds for strength and corrosion resistance.
- Special concentric, high density, polished, graphite impregnated, solid ceramic plungers are abrasion resistant and result in extended seal life.
- Specially formulated, CAT PUMP exclusive, V-Packings offers unmatched performance and seal life.
- Die cast aluminum crankcase provides high strength, minimum weight and precision tolerance control.
- Chrome-moly crankshaft gives unmatched strength and surface hardness.
- Oversized crankshaft bearings with greater loading capacity mean longer bearing life.

Easy Maintenance

- Wet-end is easily serviced without entering crankcase, requiring less time and effort.
- Valve assemblies are accessible without disturbing piping, for quick service.
- Preset packings mean no packing gland adjustment is necessary, reducing maintenance costs.

⚠ WARNING

All systems require both a primary pressure regulating device (i.e., regulator, unloader) and a secondary pressure safety relief device (i.e., pop-off valve, safety valve). Failure to install such relief devices could result in personal injury or damage to the pump or to system components. CAT PUMPS does not assume any liability or responsibility for the operation of a customer's high pressure system.

SPECIFICATIONS

U.S. Measure

Metric Measure

STANDARD SPECIFICATIONS

Flow	10 GPM	(38 L/M)
Pressure Range.....	100 to 2200 PSI	(7 to 155 BAR)
RPM	958 RPM	(958 RPM)
Inlet Pressure Range	- 5 to 60 PSI	(- 0.35 to 4 BAR)
Maximum Liquid Temperature	160°F	(71°C)

For temperatures above 130°F call CAT PUMPS for inlet conditions and elastomer recommendations.

ALTERNATE SPECIFICATIONS

Flow	★ 12 GPM	(45 L/M)
Pressure Range	★ 100 to 1800 PSI	(7 to 125 BAR)
RPM	★ 1150 RPM	(1150 RPM)
Inlet Pressure Range - ★ C.A.T. Required	★ 20 to 60 PSI	(1.4 to 4 BAR)
Maximum Liquid Temperature	★ 100°F	(38°C)

COMMON SPECIFICATIONS

Bore.....	0.945"	(24 mm)
Stroke.....	1.180"	(30 mm)
Crankcase Capacity	42 oz.	(1.26 L)
Inlet Ports (2)	3/4" NPTF	(3/4" NPTF)
Discharge Ports (2).....	1/2" NPTF	(1/2" NPTF)
Pulley Mounting	Either Side	(Either Side)
Shaft Diameter	1.181"	(30 mm)
Weight.....	44 lbs.	(19.9 kg)
Dimensions	16.28 x 12.99 x 6.44"	(413.50 x 330 x 163.50 mm)

HORSEPOWER REQUIREMENTS

FLOW		PRESSURE			MOTOR PULLEY SIZE	
		PSI 1800	PSI 2000	PSI 2200	Using 1725 RPM Motor & Std. 10" Pump Pulley	
U.S. GPM	L/M	BAR 125	BAR 140	BAR 155	RPM	Pulley O.D.
12.0	45	14.8	N/A	N/A	1150	6.5
10.0	38	12.4	13.7	15.1	958	5.4
9.0	34	11.1	12.4	13.6	836	4.9

DETERMINING THE PUMP R.P.M. $\frac{\text{Rated G.P.M.}}{\text{Rated R.P.M.}}$ = $\frac{\text{"Desired" G.P.M.}}{\text{"Desired" R.P.M.}}$

DETERMINING THE REQUIRED H.P. $\frac{\text{GPM} \times \text{PSI}}{1460}$ = Electric Brake
H. P. Required

DETERMINING MOTOR PULLEY SIZE $\frac{\text{Motor Pulley O.D.}}{\text{Pump R.P.M.}}$ = $\frac{\text{Pump Pulley O.D.}}{\text{Motor R.P.M.}}$

See complete Drive Packages [Incls: Pulleys, Belts, Hubs, Key] Tech Bulletin 003.
Refer to pump Service Manual for repair procedure and additional technical information.

"Customer confidence is our greatest asset"

PARTS LIST

ITEM	PART NUMBER		PART NUMBER		PART NUMBER		DESCRIPTION	QTY
	1050	MATL	1051	MATL	1057	MATL		
2	30067	STL	30067	STL	30067	STL	Key (M8x7.5x25))	1
5	92519	STZP	92538	S	92538	S	Screw, HHC Sems (M6x16)	8
8	43496	AL	43496	AL	43496	AL	Cover, Bearing	2
9	43520	FBR	43520	FBR	43520	FBR	Shim, Bearing Cover	2/4
	45387	S	45387	S	45387	S	Shim, Split 2-Pc	0/4
10	11340	NBR	11340	NBR	11340	NBR	O-Ring, Bearing Cover - 70D	2
11	43495	NBR	43495	NBR	43495	NBR	Seal, Oil, Crankshaft - 70D	2
15	39060	STL	39060	STL	39060	STL	Bearing, Roller	2
20	48600	TNM	48600	TNM	48600	TNM	Rod, Connecting Assembly [10/01]	3
25	43494	FCM	43494	FCM	43494	FCM	Crankshaft, Dual End	1
31	828710	—	828710	—	828710	—	Protector, Oil Cap w/Gasket	1
32	43211	ABS	43211	ABS	43211	ABS	Cap, Oil Filler	1
33	14177	NBR	14177	NBR	14177	NBR	O-Ring, Filler Cap - 70D	1
37	92241	—	92241	—	92241	—	Gauge, Oil, Bubble w/Gasket - 80D	1
38	44428	NBR	44428	NBR	44428	NBR	Gasket, Flat, Oil Gauge - 80D	1
40	92520	STZP	92542	S	92542	S	Screw, HHC Sems (M6x20)	4
48	25625	STCP	25625	STCP	25625	STCP	Plug, Drain (1/4"x19BSP)	1
49	23170	NBR	23170	NBR	23170	NBR	O-Ring, Drain Plug - 70D	1
50	43491	AL	43491	AL	43491	AL	Cover, Rear	1
51	44834	NBR	44834	NBR	44834	NBR	O-Ring, Rear Cover - 70D	1
53	43488	AL	43488	AL	43488	AL	Crankcase w/Guide Pins	1
54	27488	S	27488	S	27488	S	Pin, Guide	2
56	44664	POP	44664	POP	44664	POP	Pan, Oil, w/Screws	1
64	43507	CM	43507	CM	43507	CM	Pin, Crosshead	3
65	43501	SZZ	45258	SSZZ	45258	SSZZ	Rod, Plunger	3
69	43504	STZP	43504	STZP	43504	STZP	Washer, Oil Seal	3
70	43500	NBR	43500	NBR	43500	NBR	Seal, Oil, Crankcase - 80D	3
75	43506	S	43506	S	43506	S	Slinger, Barrier	3
88	45675	SS	45675	SS	45675	SS	Washer, Keyhole	3
89	43553	BB	45879	SS	45879	SS	Collar, Spacer	3
90	43552	CC	43552	CC	43552	CC	Plunger (M24x77)	3
95	—	SS	89651	SS	89651	SS	Stud, Plunger Retainer (M6x70)	3
96	43235	PTFE	43235	PTFE	43235	PTFE	Back-up-Ring, Plunger Retainer	3
97	17399	NBR	17399	NBR	17399	NBR	O-Ring, Plunger Retainer - 80D	3
	14160	FPM	14160	FPM	14160	FPM	O-Ring, Plunger Retainer - 80D	3
	46204	EPDM	46204	EPDM	46204	EPDM	O-Ring, Plunger Retainer - 70D	3
98	44041	SS	44041	SS	44041	SS	Gasket, Plunger Retainer	3
99	—	—	44031	SS	44031	SS	Retainer, Plunger	3
	104360	S	—	—	—	—	Retainer w/Stud	3
100	43509	POP	43509	POP	43509	POP	Retainer, Seal	3
101	43554	—	43554	—	43554	—	Wick, Long Tab	3
103	44036	S	44036	S	44036	S	Ring, Retaining	3
106	44035	NBR	44035	NBR	44035	NBR	Seal, LPS w/SS-Spg	3
	44388	FPM	44388	FPM	44388	FPM	Seal, LPS w/SS-Spg	3
	46208	EPDM	46208	EPDM	46208	EPDM	Seal, LPS w/SS-Spg	3
120	43555	BB	48464	SSNP	48464	SSNP	Case, Seal	3
121	14762	NBR	14762	NBR	14762	NBR	O-Ring, Seal Case - 70D	3
	11737	FPM	11737	FPM	11737	FPM	O-Ring, Seal Case - 75D	3
	46205	EPDM	46205	EPDM	46205	EPDM	O-Ring, Seal Case	3
126	43558	BB	48389	D	48389	D	Adapter, Female	3
	—	—	45073	SSL	45073	SSL	Adapter, Female	3
127	43559	SNG	103692	STG*	103692	STG*	V-Packing	6
128	43560	BB	45074	SSL	45074	SSL	Adapter, Male	3
139	20326	BBCP	44382	SS	44562	NAB	Plug, Inlet (3/4" NPT)	1
162	43248	PTFE	43248	PTFE	43248	PTFE	Back-up-Ring, Valve Seat	6
163	43249	NBR	43249	NBR	43249	NBR	O-Ring, Seat - 80D	6
	44383	FPM	44383	FPM	44383	FPM	O-Ring, Seat - 70D	6
	46206	EPDM	46206	EPDM	46206	EPDM	O-Ring, Seat - 70D	6
164	44718	S	44037	SS	44037	SS	Seat	6
166	43721	S	48793	SSL	48793	SSL	Valve	6
167	43751	S	44039	SS	44039	SS	Spring, Valve	6
168	44564	PVDF	44564	PVDF	44564	PVDF	Retainer, Spring	6
171	—	—	—	—	44832	S	Coil Spring, Valve Plug	6
172	17617	NBR	17617	NBR	17617	NBR	O-Ring, Valve Plug - 90D	6
	11691	FPM	11691	FPM	11691	FPM	O-Ring, Valve Plug - 90D	6
	46207	EPDM	46207	EPDM	46207	EPDM	O-Ring, Valve Plug - 70D	6
174	43851	BBCP	48463	SSNP	44831	NAB	Plug, Valve	6
185	46704	BBCP	48726	SS	46706	NAB	Head, Manifold [9/00]	1
187	14050	STZP	44005	S	44005	S	Stud, Manifold (M10x45)	4
192	12503	STZP	15847	S	15847	S	Lockwasher (M10)	4
194	81048	STZP	81258	S	81258	S	Nut, Hex (M10)	4
250	30764	NY	30764	NY	30764	NY	Protector, Shaft w/2 Screws	1
255	30264	STZP	30264	STZP	30264	STZP	Mounting, Direct (Incls: 12490, 12503, 14050, 81048)	1
260	30613	STZP	30613	STZP	30613	STZP	Rail, Angle Assy, A (Incls: 30635, 30903, 30921, 30912)	1
265	30661	—	30661	—	30661	—	Kit, Complete Mounting, U.S. (Incls: 30613, 30206, 30059, 30067, 30764)	1
269	30206	F	30206	F	30206	F	Pulley (10") AB [See Drive Packages, Tech Bulletin 003]	1
274	30059	STL	30059	STL	30059	STL	Hub, "H", M30 (Keyway M8) [See Drive Packages, Tech Bulletin 003]	1

EXPLODED VIEW

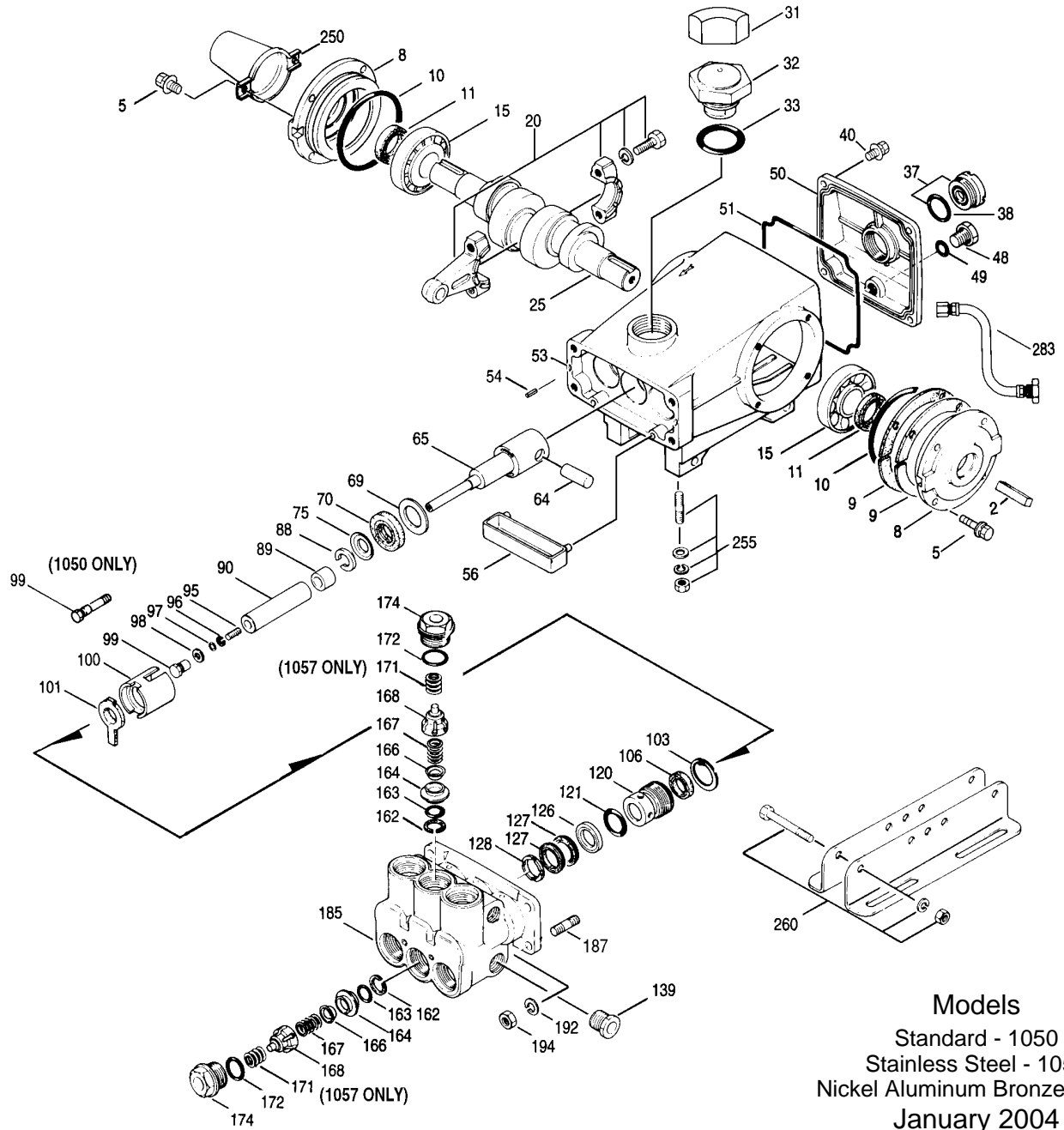

Models
 Standard - 1050
 Stainless Steel - 1051
 Nickel Aluminum Bronze - 1057
 January 2004

	1050	MATL	1051	MATL	1057	MATL		
283	34334	—	34334	—	34334	—	<i>Kit, Oil Drain</i>	1
290	—	—	6104	—	6104	—	<i>Gasket, Liquid (1 oz.)</i>	1
299	814560	BBCP	816771	SS	815261	NAB	<i>Head, Complete [9/00]</i>	1
300	30913	<i>NBR</i>	33916	<i>NBR*</i>	33916	<i>NBR*</i>	<i>Kit, Seal (Incls: 97, 103, 106, 121, 127)</i>	1
	30986	<i>FPM*</i>	30986	<i>FPM*</i>	30986	<i>FPM*</i>	<i>Kit, Seal (Incls: 97, 103, 106, 121, 127)</i>	1
	◆ 33913	<i>EPDM*</i>	◆ 33913	<i>EPDM*</i>	◆ 33913	<i>EPDM*</i>	<i>Kit, Seal (Incls: 97, 103, 106, 121, 127)</i>	1
310	34920	NBR	34387	NBR	34387	NBR	<i>Kit, Valve (Incls: 162, 163, 164, 166, 167, 168, 172)</i>	2
	31256	FPM	30987	FPM	30987	FPM	<i>Kit, Valve (Incls: 162, 163, 164, 166, 167, 168, 172)</i>	2
	◆ 31253	EPDM	◆ 31258	EPDM	◆ 31258	EPDM	<i>Kit, Valve (Incls: 162, 163, 164, 166, 167, 168, 172)</i>	2
350	30696	<i>STZP</i>	30696	<i>STZP</i>	30696	<i>STZP</i>	<i>Plier, Reverse</i>	1
351	43523	<i>STZP</i>	43523	<i>STZP</i>	43523	<i>STZP</i>	<i>Tool, Seal Case Removal</i>	1
—	6565.1	—	6565.1	—	6565.1	—	<i>Service Video</i>	1
—	6100	—	6100	—	6100	—	<i>Oil, Case (12 Bottles) ISO 68 Multi-viscosity Hydraulic (Fill to specified crankcase capacity prior to start-up)</i>	1

Bold print part numbers are unique to a particular pump model. Italics are optional items. ◆ Silicone oil/grease required.

[] Date of latest production change. *Review material codes for individual items (STG generally may be used as an alternate).

See Tech Bulletins 002, 003, 024, 027, 035, 036, 043, 045, 046, 048, 049, 052, 053, 072, 074, 077, 083, 087 and 089 for additional information.

MATERIAL CODES (Not Part of Part Number): ABS=ABS Plastic AL=Aluminum BB=Brass BBCP=Brass/Chrome Plated CC=Ceramic CM=Chrome-moly D=Delrin® EPDM=Ethylene Propylene Diene Monomer F=Cast Iron FBR=Fiber FCM=Forged Chrome-moly FPM=Fluorocarbon (Viton®)

NAB=Nickel Aluminum Bronze NBR=Medium Nitrile (Buna-N) NY=Nylon POP=Polypropylene PTFE=Pure Teflon® PVDF=Fluoroplastic (High Strength)

S=304SS SNG=Special Blend (Buna) STG=Special Blend (Teflon®) White SS=316SS SSL=316SS/Low Carbon SSZZ=316SS/Zamak STCP=Steel/Chrome Plated SSNP=316SS/Nickel Plated STL=Steel STZP=Steel/Zinc Plated SZZ=304SS/Zamak TNM=Special High Strength

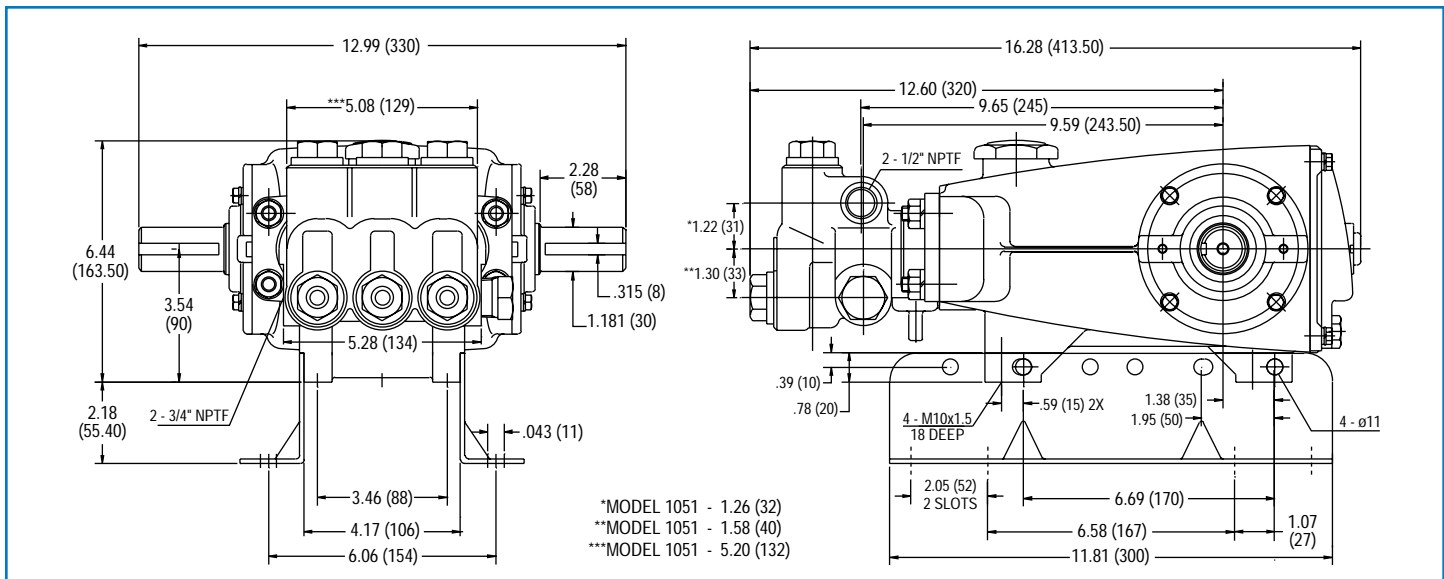

Models 1050, 1051, 1057

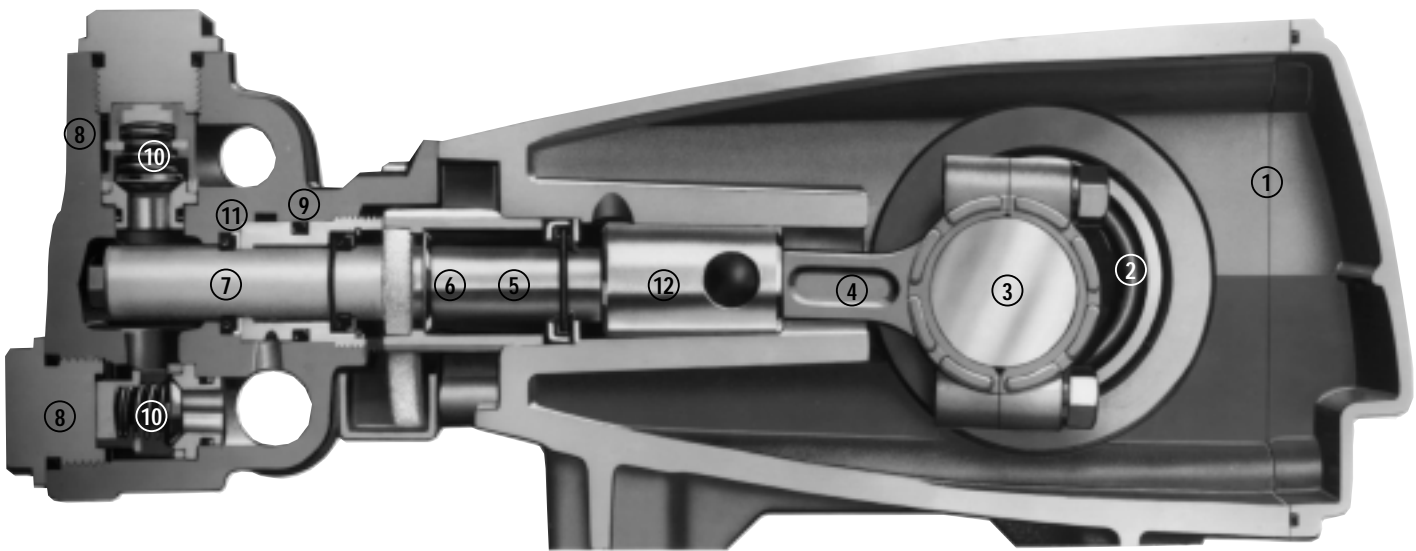

- 1 Die cast aluminum **crankcase** means high strength, lightweight, and excellent tolerance control.
- 2 Oversized crankshaft **bearings** provide extended bearing life and pump performance.
- 3 Chrome-moly **crankshaft** provides unmatched strength and surface hardness for long life.
- 4 Matched oversized high strength **connecting rods** are noted for superior strength and bearing quality.
- 5 The **plunger rods** are high tensile strength stainless steel with Zamak crossheads.
- 6 The stainless steel **slinger** provides back-up protection for the crankcase seal, keeping pumped liquids out of the crankcase.
- 7 Special concentric, high density, polished, graphite impregnated, solid ceramic **plungers** are abrasion resistant and result in extended seal life.
- 8 **Manifolds** are a high tensile strength forged brass, stainless steel or nickel aluminum bronze for long term, continuous duty.
- 9 100% wet **seal** design adds to service life by allowing pumped liquids to cool and lubricate on both sides.
- 10 Stainless steel **valves, seats and springs** provide corrosion-resistance, positive seating and long life.
- 11 Specially formulated, CAT PUMP exclusive, **V-Packings** offer unmatched performance and seal life.
- 12 **Crossheads** are 360° supported for uncompromising alignment.

Products described hereon are covered by one or more of the following U.S. patents 3558244, 3652188, 3809508, 3920356, 3930756 and 5035580

World Headquarters
CAT PUMPS
 1681 - 94th Lane N.E. Minneapolis, MN 55449-4324
 Phone (763) 780-5440 — FAX (763) 780-2958
 e-mail: techsupport@catpumps.com
 www.catpumps.com

International Inquiries
 FAX (763) 785-4329
 e-mail: intlsales@catpumps.com



CAT PUMPS (U.K.) LTD.
 1 Fleet Business Park, Sandy Lane, Church Crookham, Fleet
 Hampshire GU52 8BF, England
 Phone Fleet 44 1252-622031 — Fax 44 1252-626655
 e-mail: sales@catpumps.co.uk

N.V. CAT PUMPS INTERNATIONAL S.A.
 Heiveldekens 6A, 2550 Kontich, Belgium
 Phone 32-3-450.71.50 — Fax 32-3-450.71.51
 e-mail: cpi@catpumps.be www.catpumps.be

CAT PUMPS DEUTSCHLAND GmbH
 Buchwiese 2, D-65510 Idstein, Germany
 Phone 49 6126-9303 0 — Fax 49 6126-9303 33
 e-mail: catpumps@t-online.de www.catpumps.de